

Draffin Standard Bench Seat

88347/AL (Aluminium Seat with Back)
88339/AL (Inground/Bolt Down Aluminium Bench)
88363/AL (Freestanding/Stackable Aluminium Bench)

■ DRAFFIN ■
Street Furniture



- These are generic instructions for the installation of Draffin Street Furniture's Standard Bench Seat.
- This product should be installed by an appropriately qualified or skilled person.
- These instructions cover the assembly of various suite options, component quantities and appearances may vary.
- Further information is available by contacting Draffin Street Furniture (www.draffin.com.au) via the following QR code:



Draffin Street Furniture Website
• General product and contact information

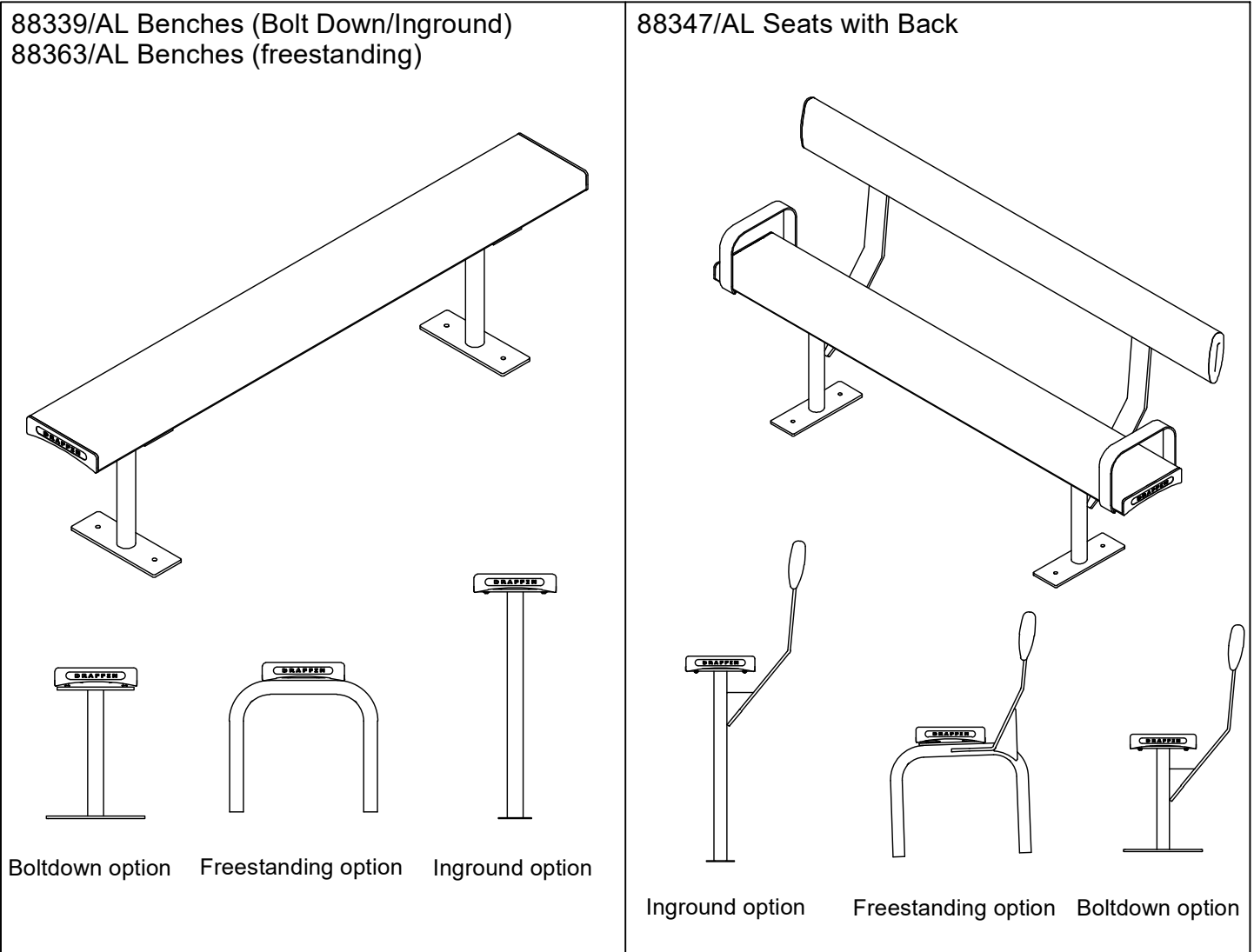

Aluminium Bench Seat

88347/AL (Aluminium Seat with Back)
 88339/AL (Inground/Bolt Down Aluminium Bench)
 88363/AL (Freestanding/Stackable Aluminium Bench)

DRAFFIN
 Street Furniture

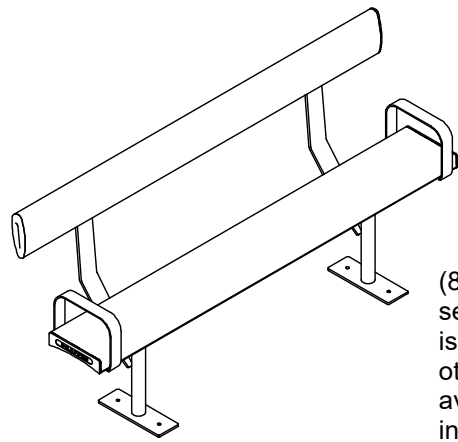

(88347/AL/B/MS/A seat with back option is shown. There are other models available, the same instructions apply)

COMPONENTS:

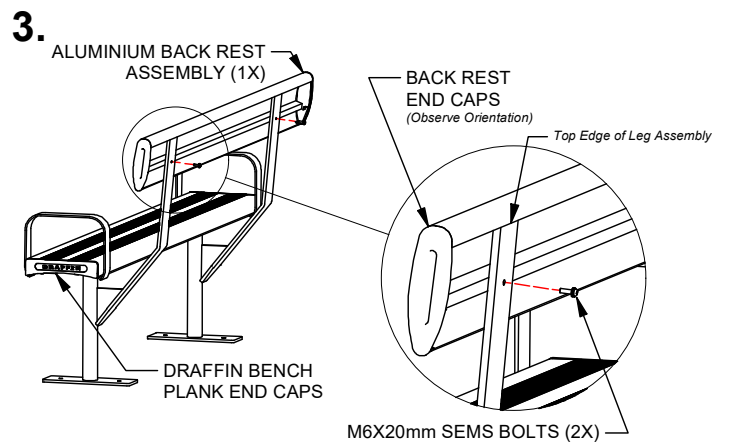
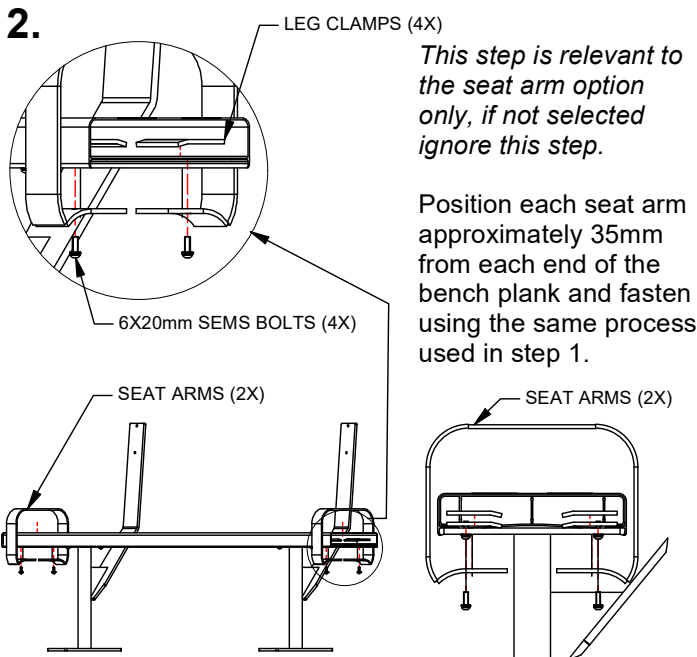
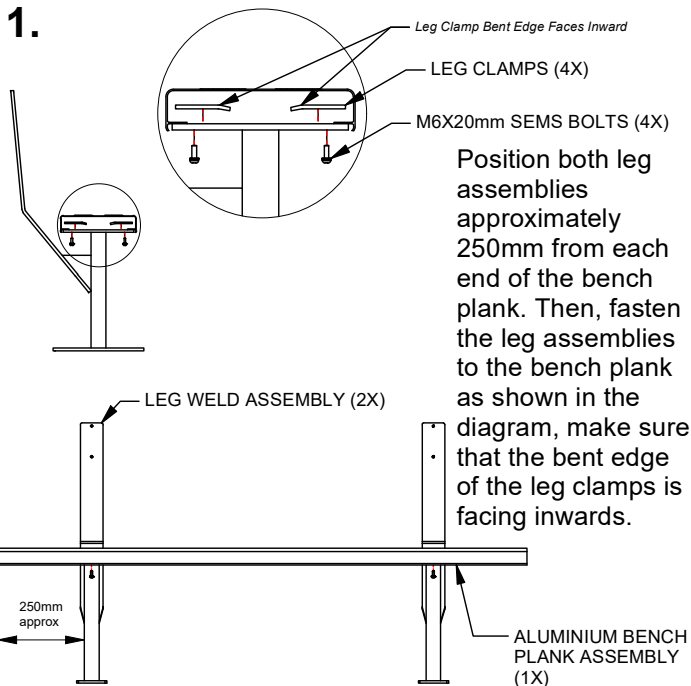
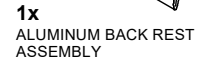
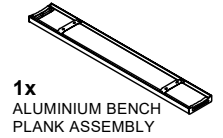
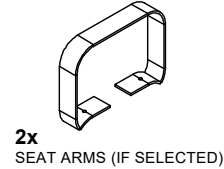
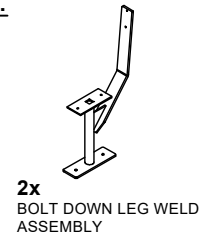

This step is relevant to the seats with backrest option only, if not selected ignore this step.

Lift and slide the aluminum back rest onto the top edge of the leg assemblies, make sure both ends are flush with the bench plank. Then fasten together as shown in diagram.

