

Wandin/Hamilton Circular Bench with 1000mm High Round Planter

DRAFFIN
Street Furniture

Model W1X/0001 - Wandin Semi Circular Bench

Model 68X14410 - Hamilton Round Planter (1000mm High) (500mm High next page)



The Hamilton Round Planter has been adapted to fit the inside diameter of the Wandin Circular Bench. This round planter measures 1000mm high, and the bench can be specified at seat, table and bar table heights.

Bench Height

- Bench Seat (430mm)
- Table Height (700mm)
- Bar Table Height (1000mm)

Bench Batten Material (See batten guide)

405mm x 40mm x 30mm

- Spotted Gum
- Enviroslat
- Anodised Aluminium
- Powdercoated Aluminium (See colour guide)
- Timber-Look Aluminium - Alpine Ash
- Timber-Look Aluminium - Mountain Gum
- Timber-Look Aluminium - Ironbark

Bench Frame Material

- Galvanised Mild Steel
- Powdercoated Gal Mild Steel (See colour guide)
- 304 Stainless Steel Brushed
- 304 Stainless Steel Bead Blasted
- 316 Stainless Steel Brushed
- 316 Stainless Steel Bead Blasted

Bench Mounting Options

- Bolt Down
- Inground
- Cantilever Leg
- Flat Bar Leg
- Concrete Plinth

Table and Bar Height - Cantilever Leg Only
Wandin Freestanding Leg - Incompatible

Other Options

- Armrests (2 per unit standard - as pictured)

Planter Material

- Weathering Steel
- Powdercoated Mild Steel (See colour guide)
- 304 Stainless Steel Brushed
- 316 Stainless Steel Brushed

Wandin Semi-Circular Bench x 2

(2 x Semi-Circular Benches create a full circle)
and

Hamilton Round Planter

(1440mm Diameter x 1000mm High)

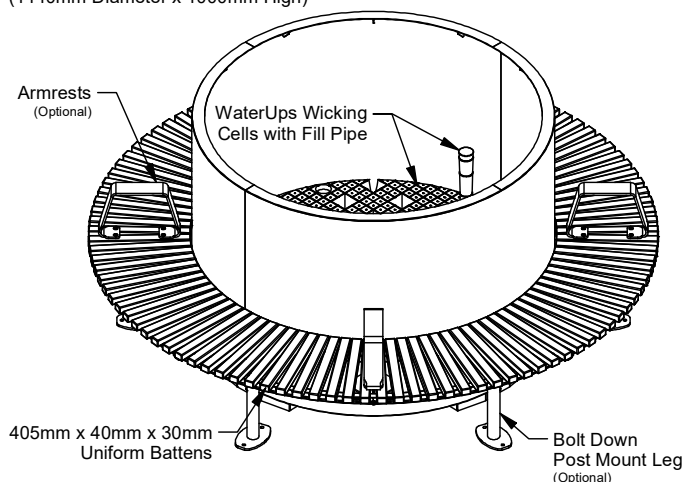
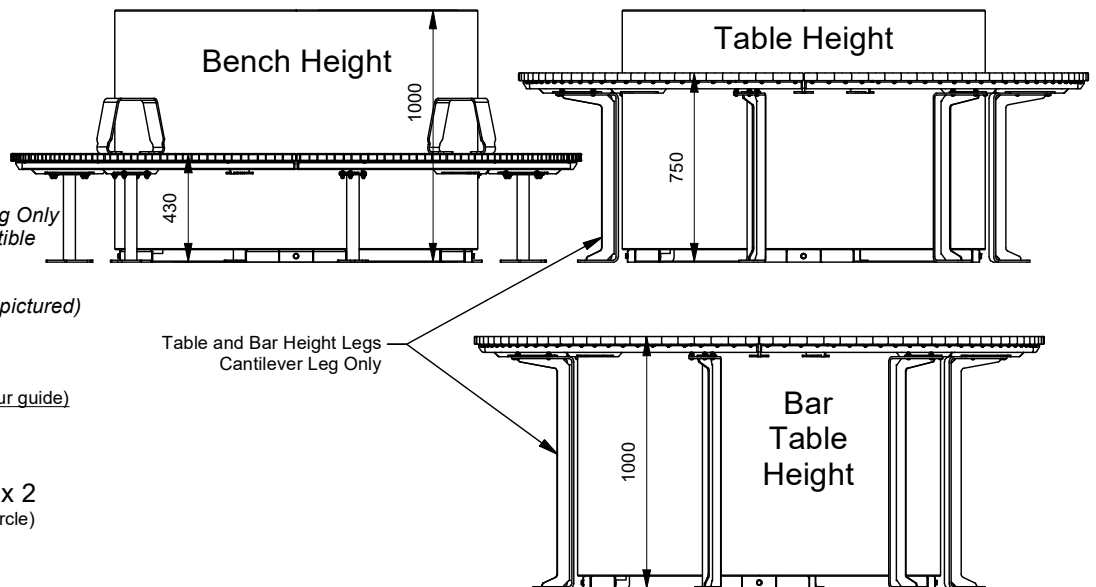
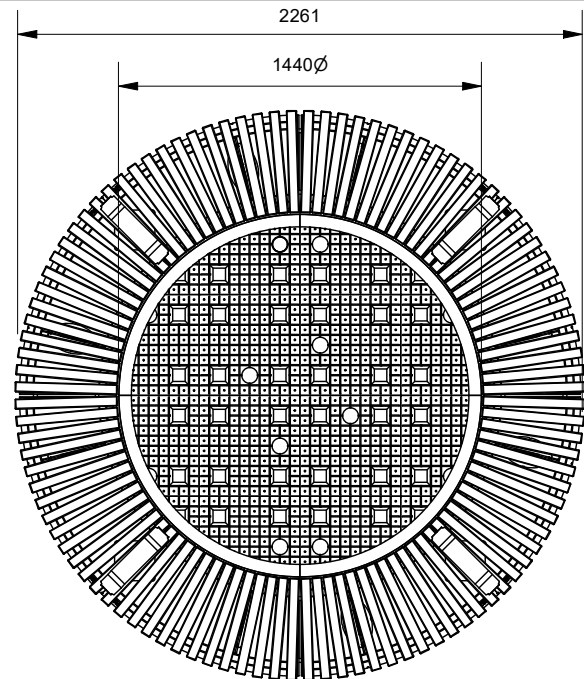

More information:
Go to the website for spec inspiration.

W1X/0001 - Wandin Semi Circular Bench
68X14410 - Hamilton Round Planter (1000mm High)
<https://draffin.com.au/product/hamiltonwandin-round-planter-bench/>

Batten Guide
<https://draffin.com.au/batten-guide/>

Colour and Plinth Guide
<https://draffin.com.au/colour-guide/>

Stainless Steel Guide
<https://draffin.com.au/stainless-steel-guide/>

Wandin Architectural Guide
<https://draffin.com.au/wandin-architectural-guide/>

DDA guide
<https://draffin.com.au/dda/>

Wandin/Hamilton Circular Bench with 500mm High Round Planter

Model W1X/0001 - Wandin Semi Circular Bench
Model 68X14405 - Hamilton Round Planter (500mm High)



The Hamilton Round Planter has been adapted to fit the inside diameter of the Wandin Circular Bench. This round planter measures 500mm high.

Bench Batten Material (See batten guide)

405mm x 40mm x 30mm

- Spotted Gum
- Enviroslat
- Anodised Aluminium
- Powdercoated Aluminium (See colour guide)
- Timber-Look Aluminium - Alpine Ash
- Timber-Look Aluminium - Mountain Gum
- Timber-Look Aluminium - Ironbark

Bench Frame Material

- Galvanised Mild Steel
- Powdercoated Gal Mild Steel (See colour guide)
- 304 Stainless Steel Brushed
- 304 Stainless Steel Bead Blasted
- 316 Stainless Steel Brushed
- 316 Stainless Steel Bead Blasted

Bench Mounting Options

- Bolt Down
 - Inground
 - Cantilever Leg
 - Flat Bar Leg
 - Concrete Plinth
- Wandin Freestanding Leg - Incompatible*

Other Options

- Armrests (2 per unit standard - as pictured)

Planter Material

- Weathering Steel
- Powdercoated Mild Steel (See colour guide)
- 304 Stainless Steel Brushed
- 316 Stainless Steel Brushed

Wandin Semi-Circular Bench x 2

(2 x Semi-Circular Benches create a full circle)
and

Hamilton Round Planter

(1440mm Diameter x 500mm High)

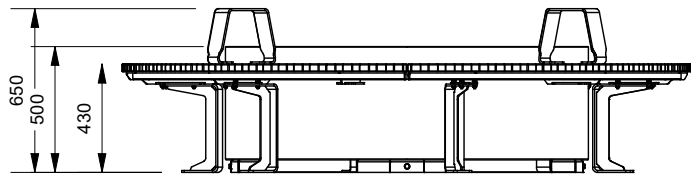
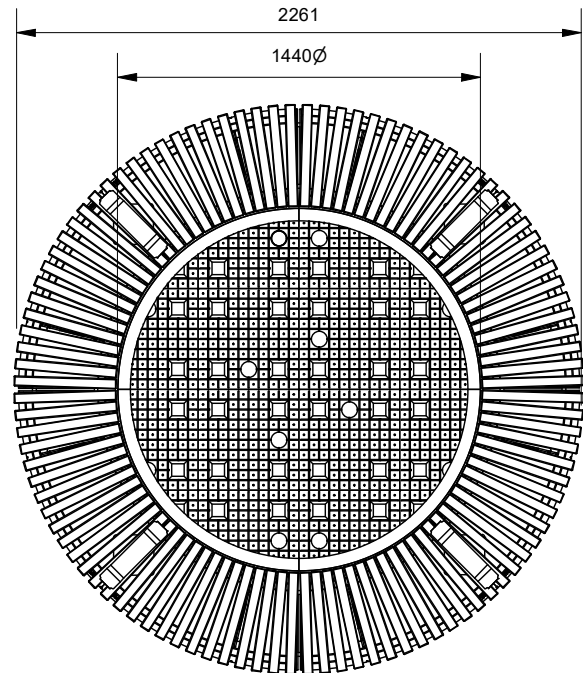
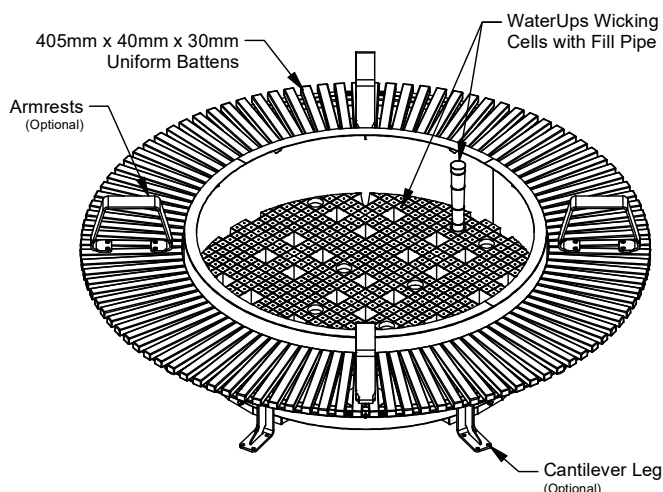

Semi-Circular Bench Leg Types

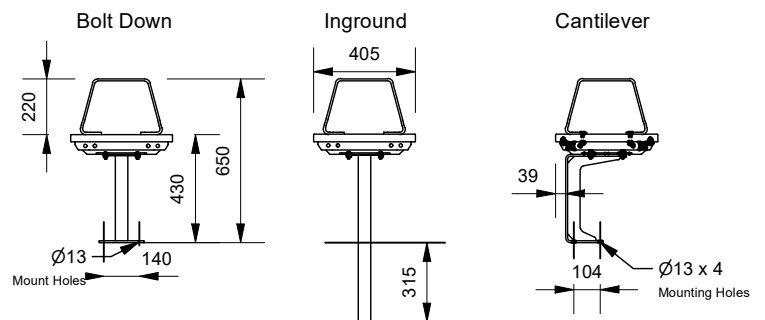

Flat Bar Leg

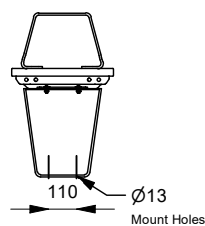

Concrete Plinth

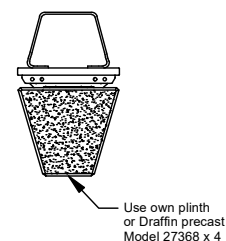

Wandin Semi Circular Bench

Model W1X/0001 - Wandin Semi Circular Bench

DRAFFIN
Street Furniture



Assembly

The Semi-Circular Bench is shipped in halves to save on freight volume. Once delivered, the bench will require assembly. The bench can be configured as a single semi-circular unit or fixed to another semi-circular unit for full circle applications. Two spacers are provided per semi-circle unit to join the half units together.

For semi-circular configuration: Bring halves together using the supplied **spacer with mount** between each half. Use supplied fasteners to fix units together.

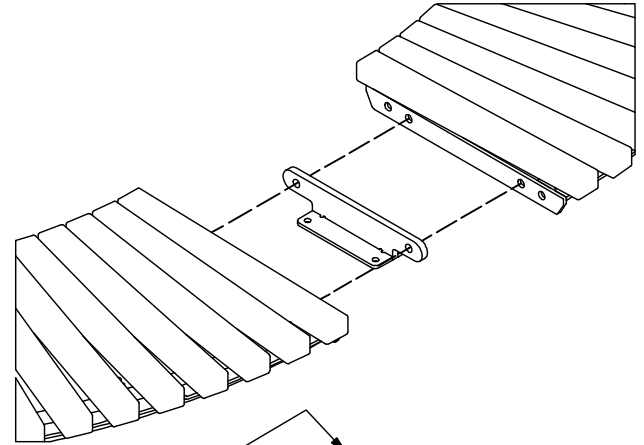
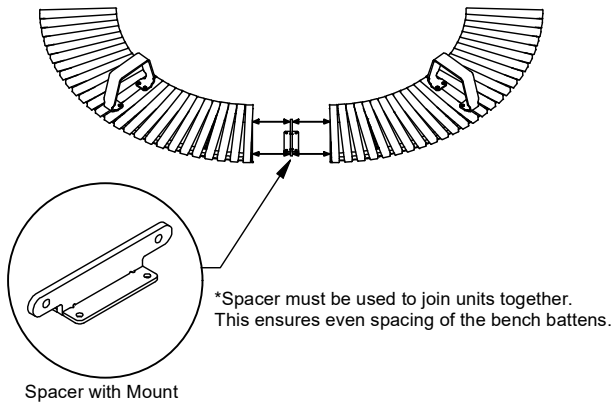

For full circle configuration: Assemble halves (as above) using spacer with mount, then bring assembled semi-circles together using a supplied standard spacer (pictured below) between each semi-circle. Use supplied fasteners to fix units together.

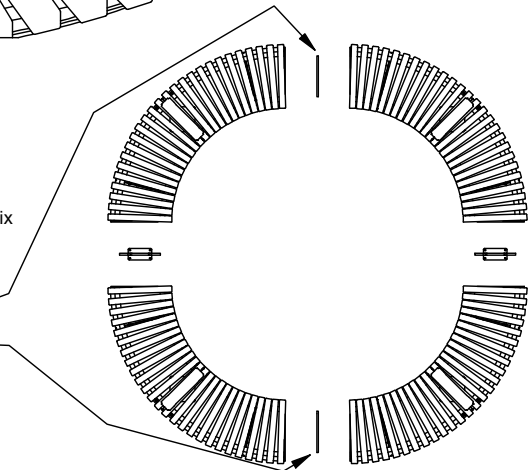
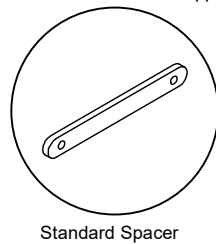

Leg Placement

Depending on the application, the leg placement will change to ensure best performance and stability. This applies to all leg types in the Wandin range except the plinth mount variant.

Semi-Circular Bench

3 Legs per unit.

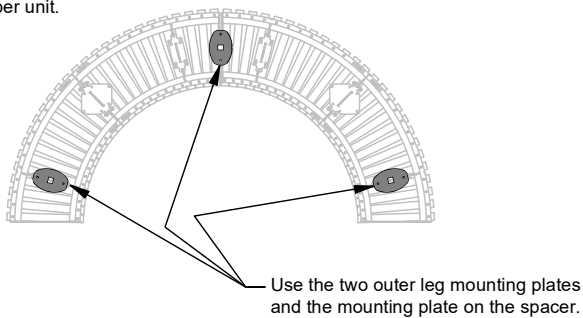

Full Circle Bench

Semi-Circular Bench x 2
3 Legs per unit.

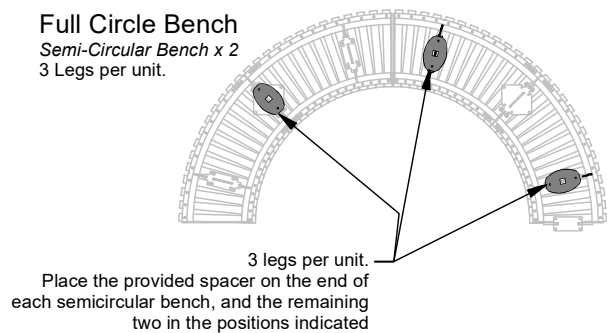

Even leg spacing can be achieved using the above recommended leg mounting positions.

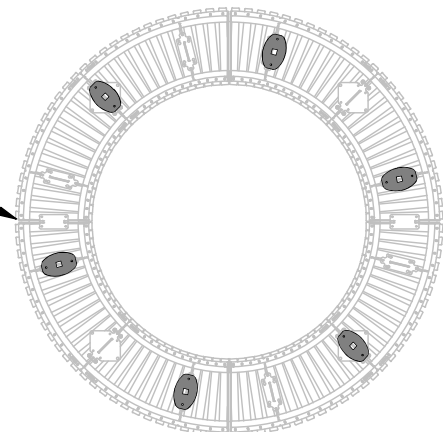

Hamilton Round Planter

68x14405 - Ø1440mm x 500mm High Hamilton Round Planter
 68x14410 - Ø1440mm x 1000mm High Hamilton Round Planter



All Hamilton Planters incorporate WaterUps™ wicking cells that make setting up a wicking garden planter easy. A built in overflow pipe prevents overfilling the planter ensuring ideal soil hydration. Plus Hamilton Planters also employ a hideaway mounting system that also makes installation simple.

Watering Management

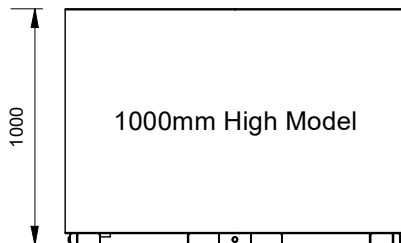
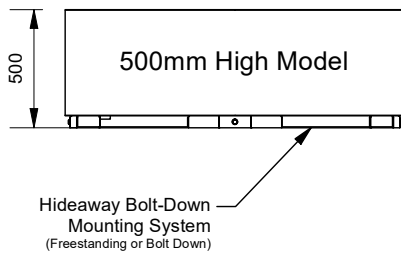
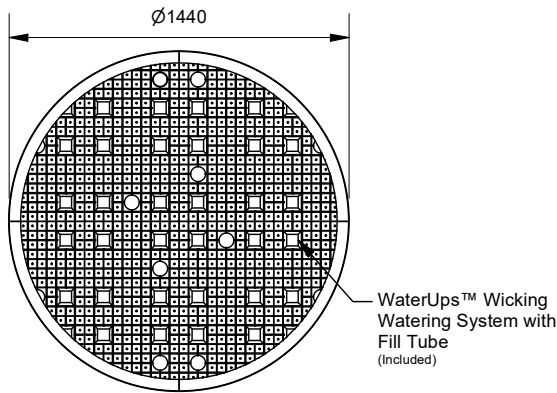
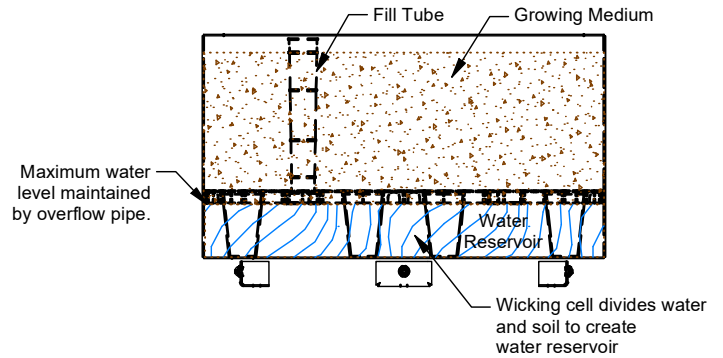

Mounting

1. Fix footing to surface
 Recommended minimum 100mm anchor for installation

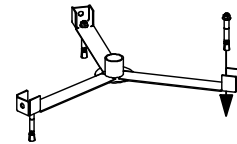

2. Locate planter over footing.

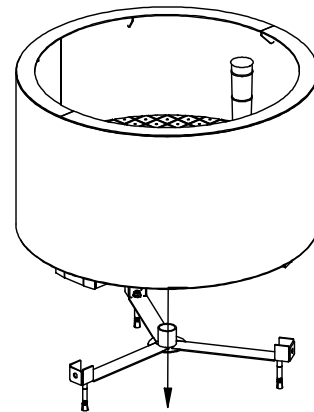

3. Bolt through footing to fix

