

Curved Park Bench

Model 88663 - Curved Park Bench

DRAFFIN
Street Furniture



Lightweight and graceful in appearance with rugged and heavy-duty reliability built-in. 40mm x 30mm battens wrap the galvanised mild steel frame profile to form comfortable curved seating. Curved Park Benches fit right in whether placed on the street or in the park.

Batten Material (See batten guide)

40mm x 30mm

- Spotted Gum
- Enviroslat Composite
- Anodised Aluminium
- Powdercoated Aluminium (See colour guide)
- Timber-Look Aluminium - Alpine Ash
- Timber-Look Aluminium - Mountain Gum
- Timber-Look Aluminium - Ironbark

Mounting Options

- Bolt Down
- Inground

Other Options

- Custom Dimensions

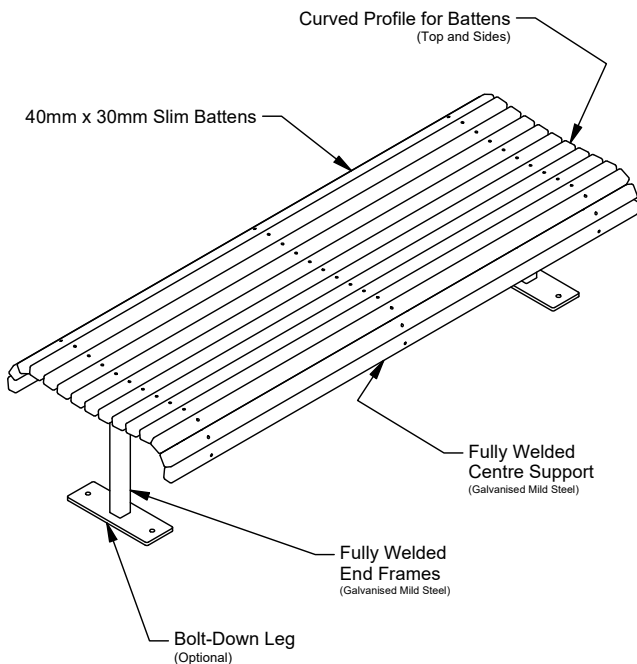
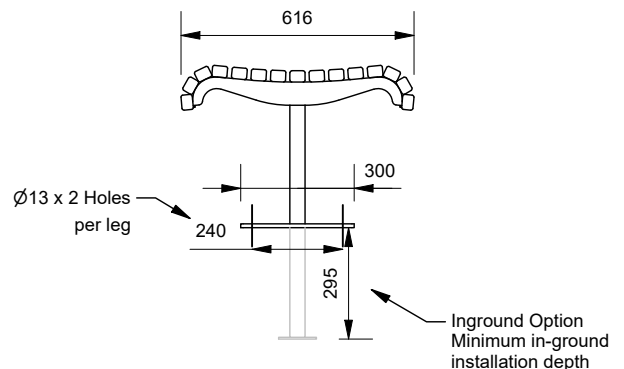
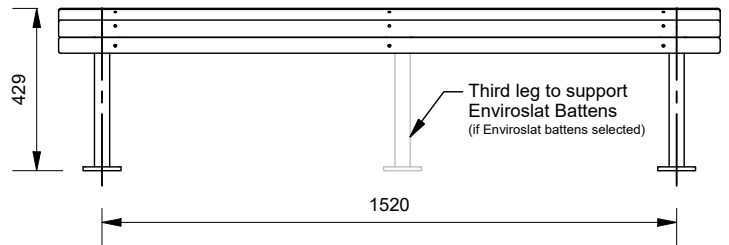
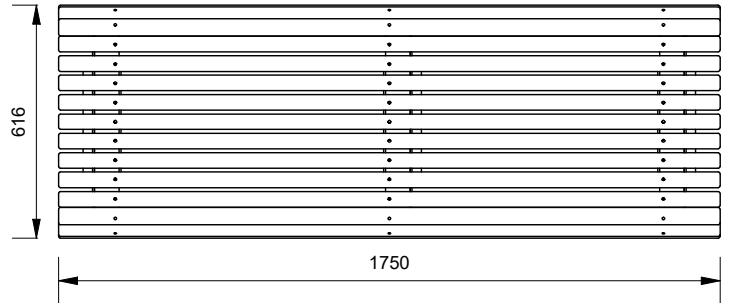

More information:
Go to the website for spec inspiration.
88663 - Curved Park Bench
<https://draffin.com.au/product/curved-park-bench/>

Batten Guide
<https://draffin.com.au/batten-guide/>

Colour Guide
<https://draffin.com.au/colour-guide/>

DDA guide
<https://draffin.com.au/dda/>