

# Arena 120lt Bin Surround

1600 Series - Arena Single Bay 120lt Bin Surround

**DRAFFIN**  
Street Furniture



The Arena Bin Surround is designed for easy cleaning and maintenance. A sleek fully welded all-stainless steel construction for high strength and reduced joints where dirt and germs can accumulate.

#### Size

- 120lt

#### Cover Style

- Dome
- Sloped Forward
- Sloped Backward

#### Opening

- Rectangle Frogmouth
- Recycle Frogmouth

#### Lock System

- Cam Lock (8mm Tri-Key)
- Magnetic Latch

#### Other Options

- Magnetic Door Latches (with Handles)
- Laser Cut Logos
- Logo Backing Plates
- Adjustable Leveling Foot Straps
- Communication Signage (See Signage Guide)

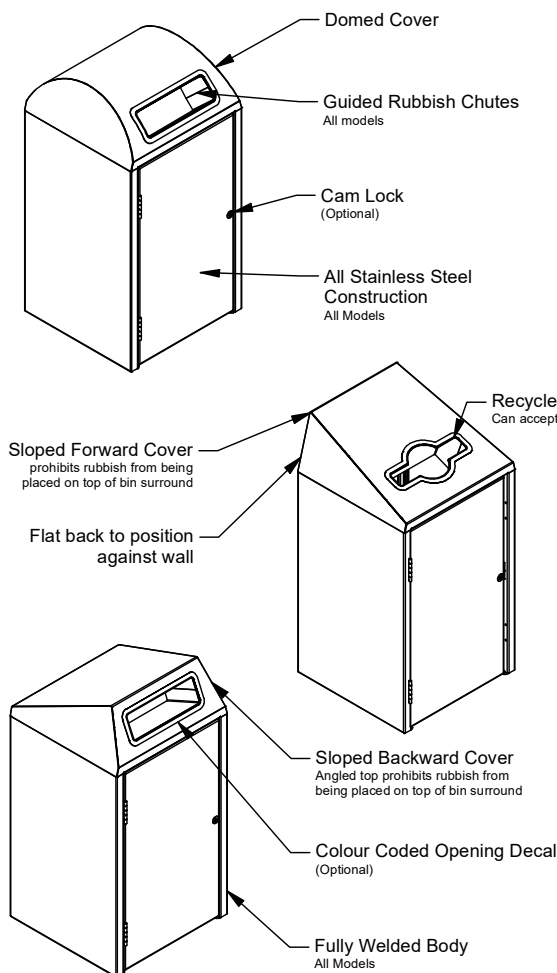
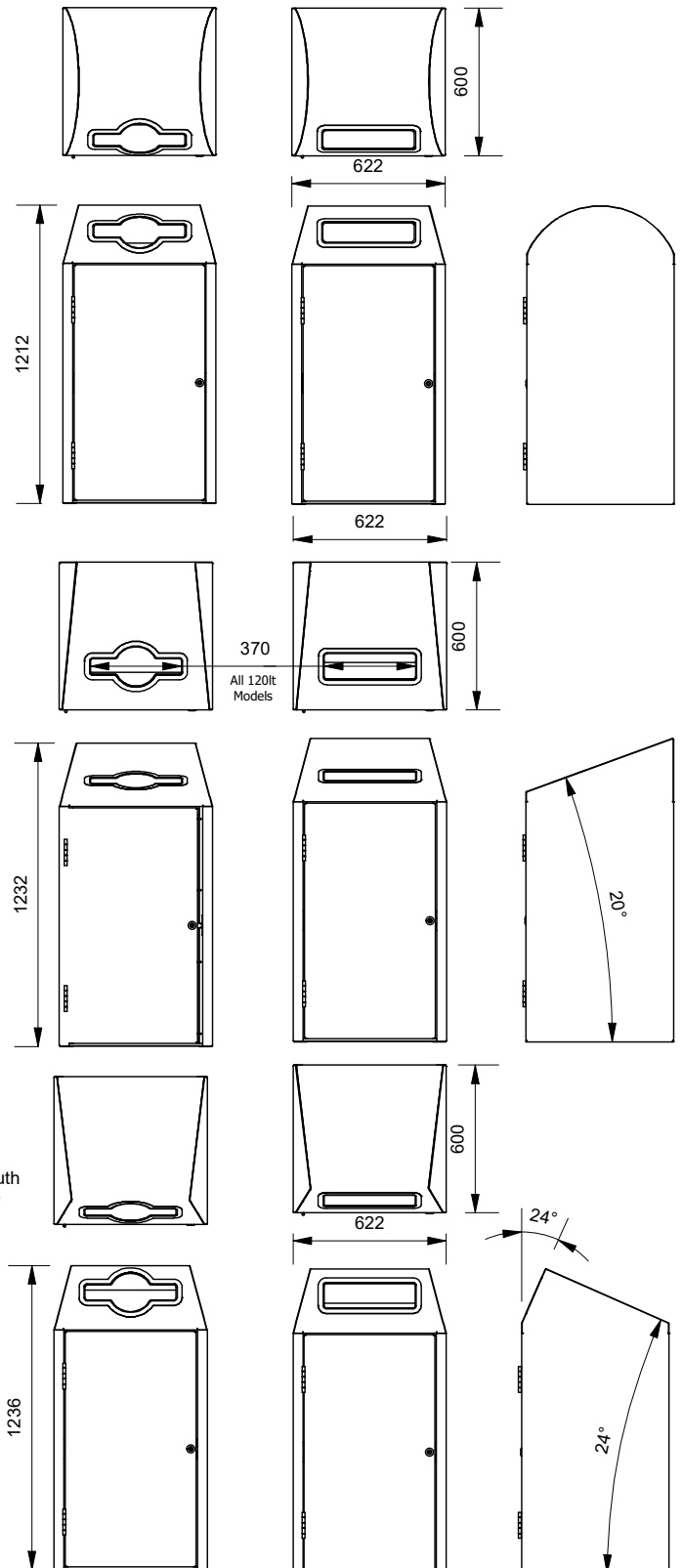

More information:  
Go to the website for spec inspiration.  
**1600 Series 120lt Arena Bin Surround**  
<https://draffin.com.au/product/arena-bin/>

Stainless Steel Guide  
<https://draffin.com.au/stainless-steel-guide/>

Signage Guide  
<https://draffin.com.au/signage-guide/>

# Arena 120lt Bin Surround

1600 Series - Arena Dual Bay 120lt Bin Surround

**DRAFFIN**  
Street Furniture



The Arena Bin Surround is designed for easy cleaning and maintenance. A sleek fully welded all-stainless steel construction for high strength and reduced joints where dirt and germs can accumulate.

#### Size

- 120lt (Dual)

#### Cover Style

- Dome
- Sloped Forward
- Sloped Backward

#### Opening

- Rectangle Frogmouth
- Recycle Frogmouth

#### Lock System

- Cam Lock (8mm Tri-Key)
- Magnetic Latch

#### Other Options

- Magnetic Door Latches (with Handles)
- Laser Cut Logos
- Logo Backing Plates
- Adjustable Leveling Foot Straps
- Communication Signage (See Signage Guide)

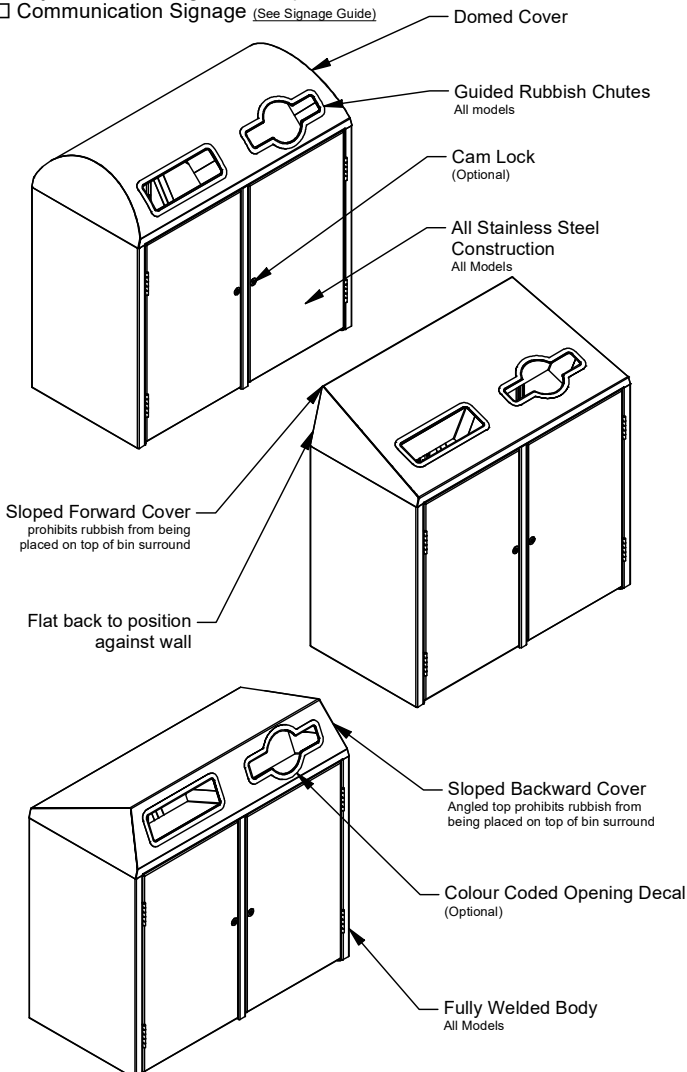
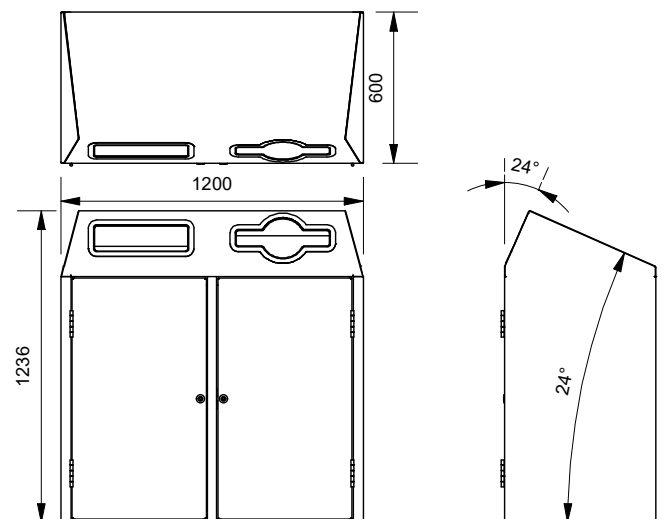
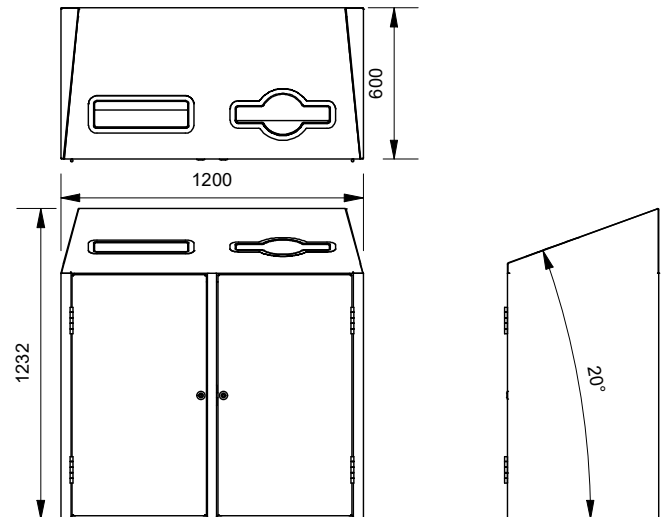
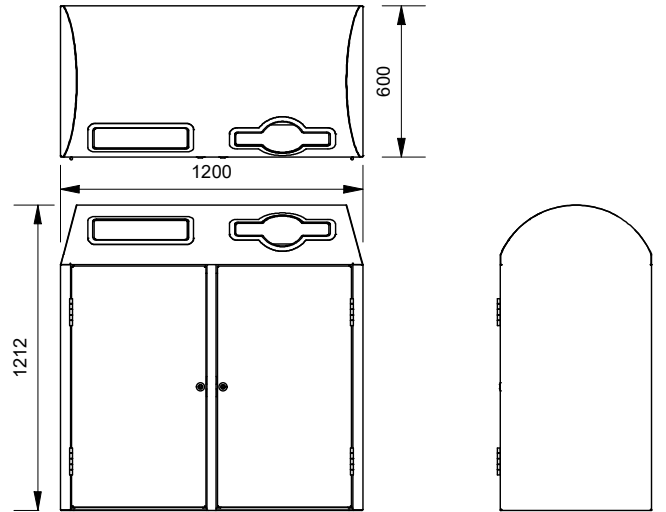

More information:  
Go to the website for spec inspiration.  
**1600 Series 120lt Arena Bin Surround**  
<https://draffin.com.au/product/arena-bin/>

Stainless Steel Guide  
<https://draffin.com.au/stainless-steel-guide/>

Signage Guide  
<https://draffin.com.au/signage-guide/>

# Arena 240lt Bin Surround

1600 Series - Arena Single Bay 240lt Bin Surround

**DRAFFIN**  
Street Furniture



The Arena Bin Surround is designed for easy cleaning and maintenance. A sleek fully welded all-stainless steel construction for high strength and reduced joints where dirt and germs can accumulate.

#### Size

- 240lt

#### Cover Style

- Dome
- Sloped Forward
- Sloped Backward

#### Opening

- Rectangle Frogmouth
- Recycle Frogmouth

#### Lock System

- Cam Lock (8mm Tri-Key)
- Magnetic Latch

#### Other Options

- Magnetic Door Latches (with Handles)
- Laser Cut Logos
- Logo Backing Plates
- Adjustable Leveling Foot Straps
- Communication Signage (See Signage Guide)

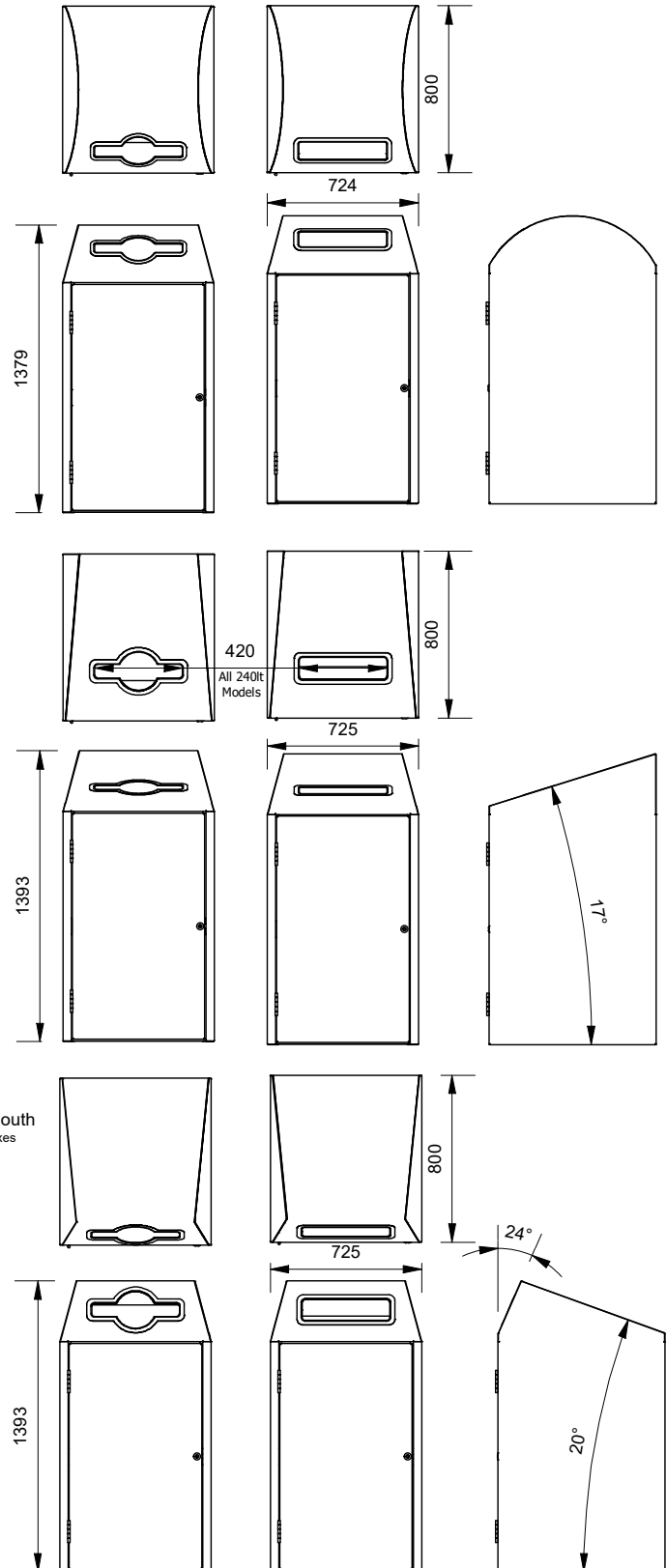
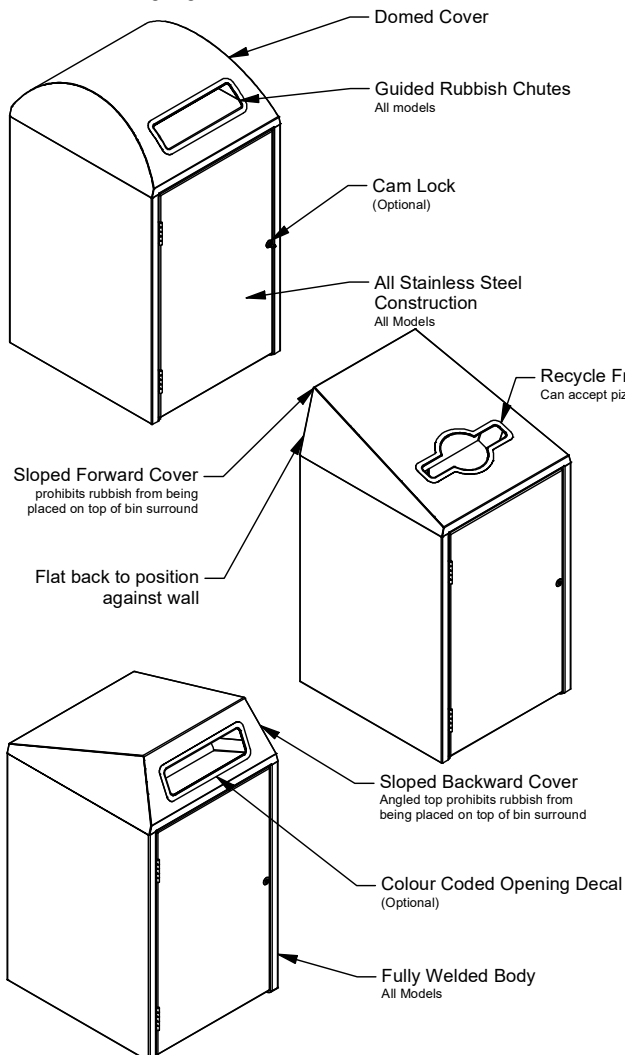

More information:  
Go to the website for spec inspiration.  
**1600 Series 240lt Arena Bin Surround**  
<https://draffin.com.au/product/arena-bin/>

Stainless Steel Guide  
<https://draffin.com.au/stainless-steel-guide/>

Signage Guide  
<https://draffin.com.au/signage-guide/>

# Arena 240lt Bin Surround

1600 Series - Arena Dual Bay 240lt Bin Surround

**DRAFFIN**  
Street Furniture



The Arena Bin Surround is designed for easy cleaning and maintenance. A sleek fully welded all-stainless steel construction for high strength and reduced joints where dirt and germs can accumulate.

#### Size

- 240lt (Dual)

#### Cover Style

- Dome
- Sloped Forward
- Sloped Backward

#### Opening

- Rectangle Frogmouth
- Recycle Frogmouth

#### Lock System

- Cam Lock (8mm Tri-Key)
- Magnetic Latch

#### Other Options

- Magnetic Door Latches (with Handles)
- Laser Cut Logos
- Logo Backing Plates
- Adjustable Leveling Foot Straps
- Communication Signage (See Signage Guide)

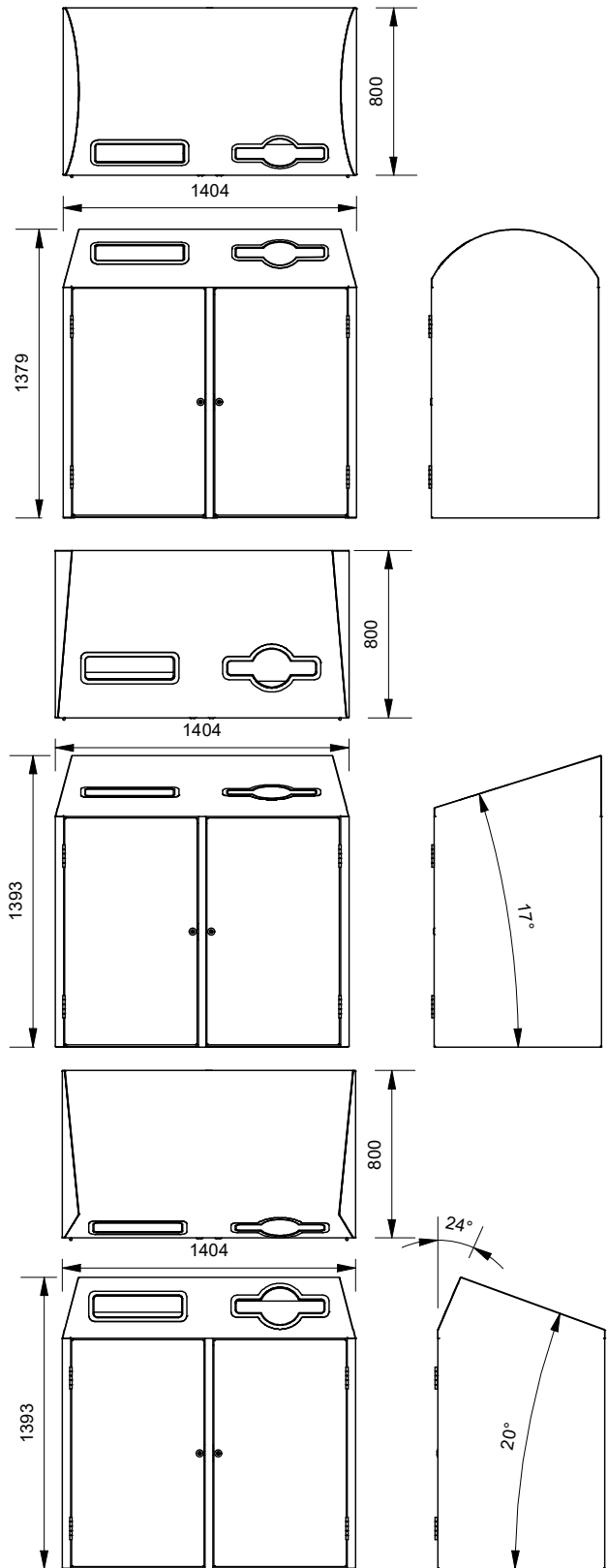
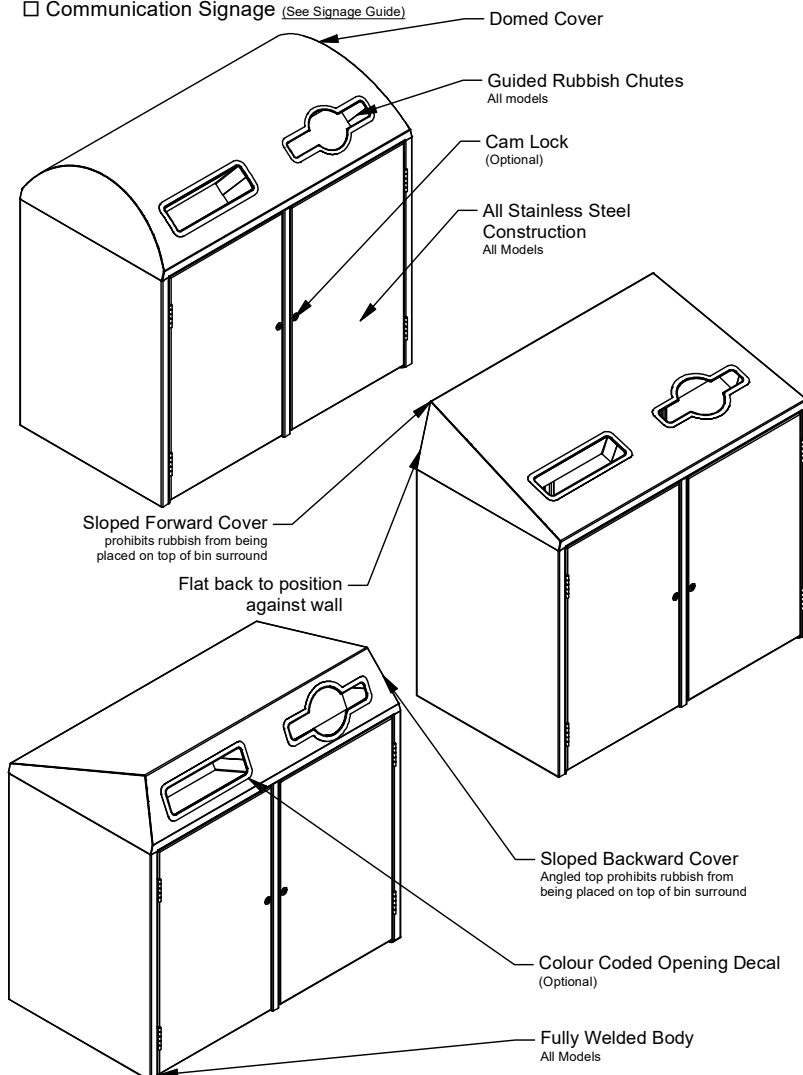

More information:  
Go to the website for spec inspiration.  
**1600 Series 240lt Arena Bin Surround**  
<https://draffin.com.au/product/arena-bin/>

Stainless Steel Guide  
<https://draffin.com.au/stainless-steel-guide/>

Signage Guide  
<https://draffin.com.au/signage-guide/>