

Hamilton Round Planter

68x - Hamilton Round Planter

DRAFFIN
Street Furniture



Hamilton Round Planters take their design cue from the popular Hamilton square planter range, with two planter heights and diameter sizes available to choose from. Hamilton round planters also include WaterUps™ wicking cells to regulate watering and maintain plant health.

Round Planter Diameter

- 500mm
- 800mm

Round Planter Height

- 500mm
- 1000mm

Planter Material

- 304 Stainless Steel
- 316 Stainless Steel
- Powdercoated
- Weathering Steel

Mounting Options

- Freestanding
- Bolt Down

Other Options

- Without Waterups Wicking System

500mm Diameter Planters

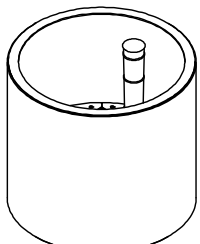

500mm Height

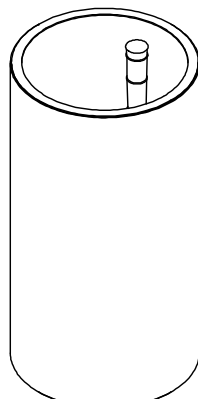

1000mm Height

800mm Diameter Planters

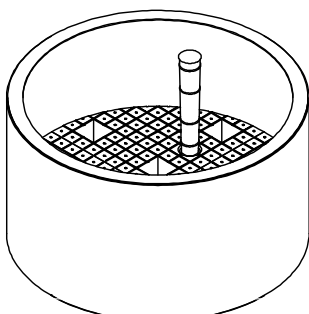

500mm Height

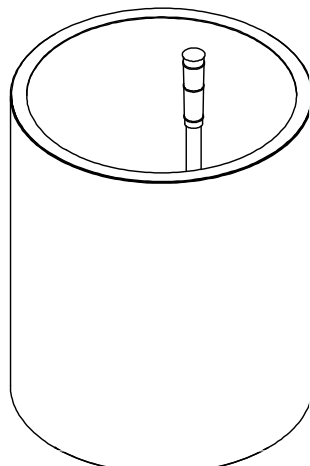

1000mm Height

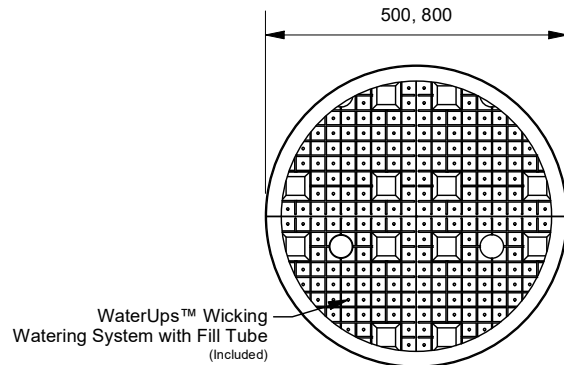

WaterUps™ Wicking Watering System with Fill Tube (Included)

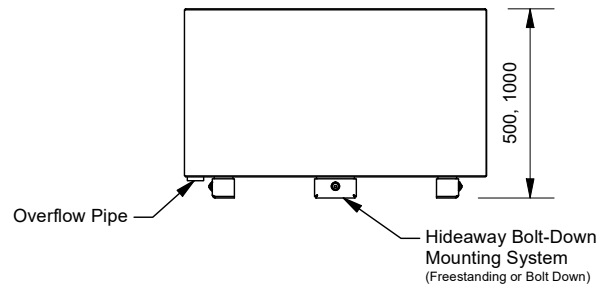

Watering Management

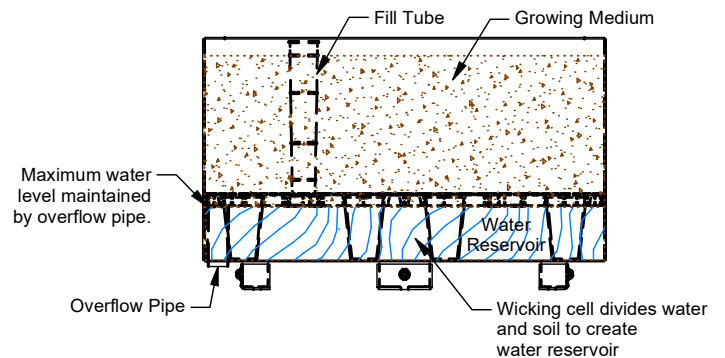

Mounting

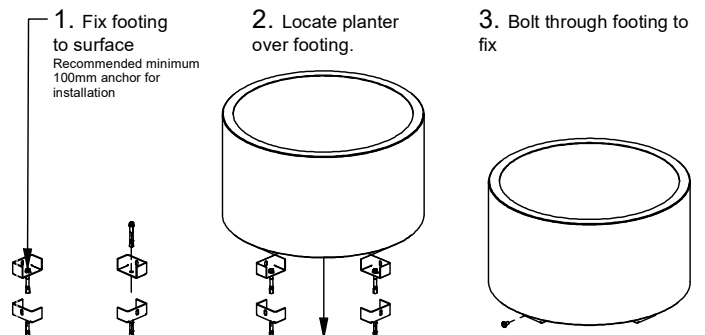

More information:
Go to the website for spec inspiration.

68x - Hamilton Round Planter
<https://draffin.com.au/product/hamilton-round-planter/>

Colour Guide
<https://draffin.com.au/colour-guide/>

Stainless Steel Guide
<https://draffin.com.au/stainless-steel-guide/>

Weathering Steel Guide
<https://draffin.com.au/weathering-steel-guide/>